

Water dispenser Lunaris®

**Chilled still and
sparkling water.**



Lunaris®

Flexible application possibilities.

***Lunaris® T-CS 20/60 dimensions (height × width × depth):**

T-CS 20:
42.5 × 19.5 × 51.7 cm

T-CS 60:
53.5 × 21.0 × 52.8 cm

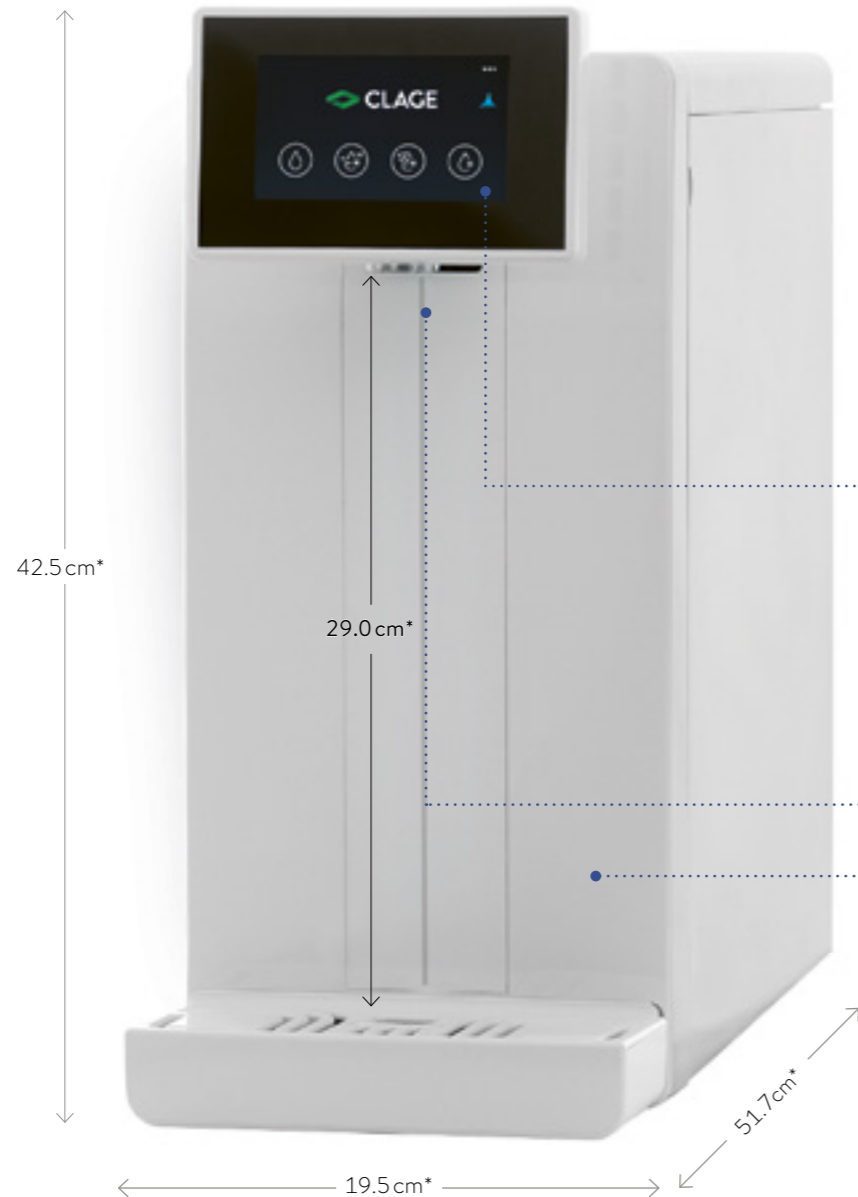

Still or still chilled water: Press and hold the still or still chilled water selection button until the glass or carafe contains the desired amount of water.*

*Carafe filling can be set as an option during installation.



Chilled medium or classic sparkling water: Press and hold the chilled medium or classic sparkling water selection button until the glass or carafe contains the desired amount of water.*

*Optional carafe filling and CO₂ content can be specified during installation.



Filling a glass with still or still chilled water: Press the glass selection button. Press and hold the still or still chilled water selection button until the glass contains the desired amount of water.



Filling a glass with chilled sparkling water: Press the glass selection button. Press and hold the sparkling water selection button until the glass contains the desired amount of water.*

*CO₂ content can be set during installation.

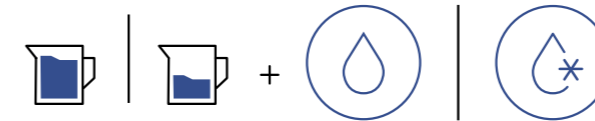

Filling the carafe with still or still chilled water: Press the selection button for full or half filling of the carafe. Press the selection button for still or still chilled water.

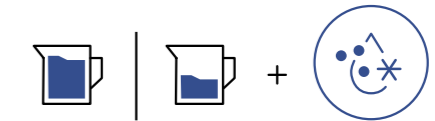

Filling the carafe with chilled sparkling water: Press the selection button for full or half filling of the carafe. Press the selection button for sparkling water.*

*CO₂ content can be set during installation.



Touch Display

The 4.3-inch touch display offers simple and intuitive operation.

Water dispensing

Safe and clean dispensing area thanks to the innovative Tyfon® system.



Water filter

With activated carbon filter system with integrated high-performance pre-filtration to reduce particles, off-flavour components and chlorine.

Installation and function

Please note: The drinking water quality must comply with the currently valid Drinking Water Ordinance at the angle valve.

Use only food-grade CO₂ (E290).

The water hardness should be at least 5° dH carbonate hardness and have a conductivity of at least 300 µS/cm.

- Water outlet height 290 mm
- Distance behind the appliance at least 100 mm
- Electrical connection with plug 230V AC 50Hz
- CO₂ hose length 2000 mm
- Water hose length 2500 mm
- Power cable length 1500 mm

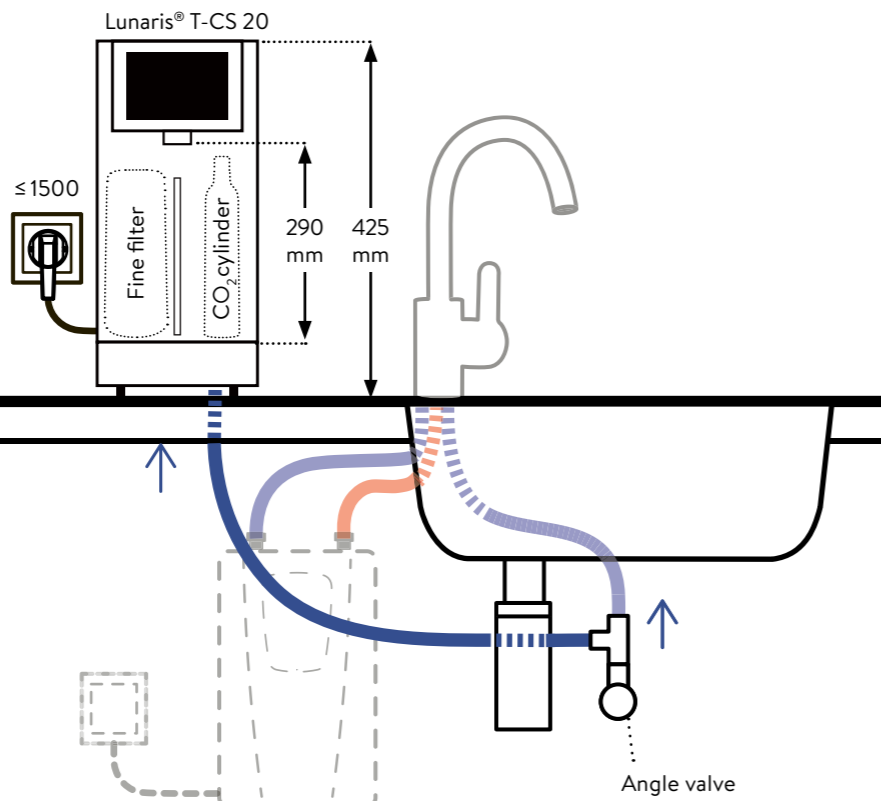
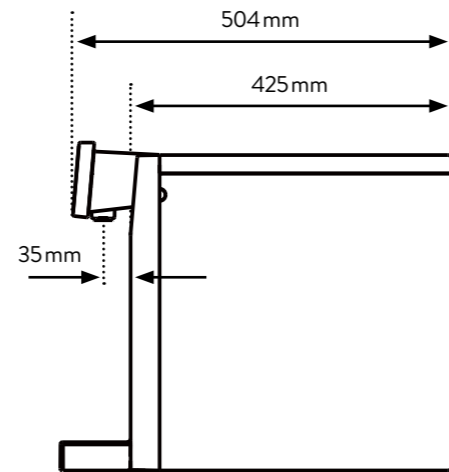

Lunaris® T-CS 20



Lunaris® T-CS 20 white Lunaris® T-CS 20 black

The Lunaris® T-CS 20 tabletop water dispenser provides up to **20 litres per hour of consistently chilled and carbonated water. Perfect for small offices, medical practices, staff rooms or nurseries.**

- > Electronic water system for supplying filtered table water, optionally unchilled, chilled still, medium or strongly sparkling, for direct connection to an angle valve.
- > Touch display for menu control and water selection
- > Supplies up to 30 people
- > Uses R600a refrigerant to meet all environmental and climate protection requirements
- > Efficient and powerful, the patented COOL-HYBRID® System combines the advantages of ice banks and dry cooling (30% higher cooling capacity and **up to 30% energy savings compared to conventional water dispensers**).
- > The patented KARBONY® System produces up to 2.2 litres of sparkling water in just 35 seconds with the **perfect balance between water temperature and carbon dioxide content.**
- > **Triple protection against germs:** the Tyfon® System uses three technologies to keep the machine, dispenser and drip tray germ-free
- > Up to 20 litres per hour of consistently chilled and sparkling water
- > Comprehensive connection accessories such as Vario-san additional device valve (for additional connection to an already occupied water connection), water stop for additional safety, backflow preventer in accordance with DIN EN 1717 and other necessary connection accessories
- > Everything included: **LSF water filter and 600 g disposable CO₂ cylinder are included in the scope of delivery**



| Lunaris® T-CS 20 | |
|---|---------------------------------------|
| Function: | |
| Number of users: | < 30 |
| Water connection (thread connection): | G 3/4" |
| Zulässiger Wasserdruck [bar]: | 2.0 – 6.0 |
| Zulässiger CO ₂ -Druck [bar]: | 3.0 – 5.5 |
| Temperature of cooled water [°C]: | 4 – 12 |
| Chilled water capacity [glasses ²⁾ / h]: | 100 |
| Standby power consumption [kWh / 24h]: | 0.25 |
| Nominal power at voltage 1~/N/PE 230 V AC [kW]: | 0.17 |
| Power cable: | with plug |
| Current [A]: | 0.7 |
| Protection class: | IP 22 |
| Weight (empty) [kg], approx.: | 20 |
| Dimensions (height × width × depth) [cm]: | 42.5 × 19.5 × 51.7 |
| Compact tabletop unit [colour]: | white black |
| Part number: | 4100-45000 4100-45001 |

Retail box: 10 × 55 × 36.5 cm / 2,10 kg PU = 1 1) Standard glass with 200 ml

Installation and function

Please note: The drinking water quality must comply with the currently valid Drinking Water Ordinance at the angle valve.

Use only food-grade CO₂ (E290).

The water hardness should be at least 5° dH carbonate hardness and have a conductivity of at least 300 µS/cm.

- Water outlet height 290 mm
- Distance behind the appliance at least 100 mm
- Electrical connection with plug 230V AC 50Hz
- CO₂ hose length 2000 mm
- Water hose length 2500 mm
- Power cable length 1500 mm

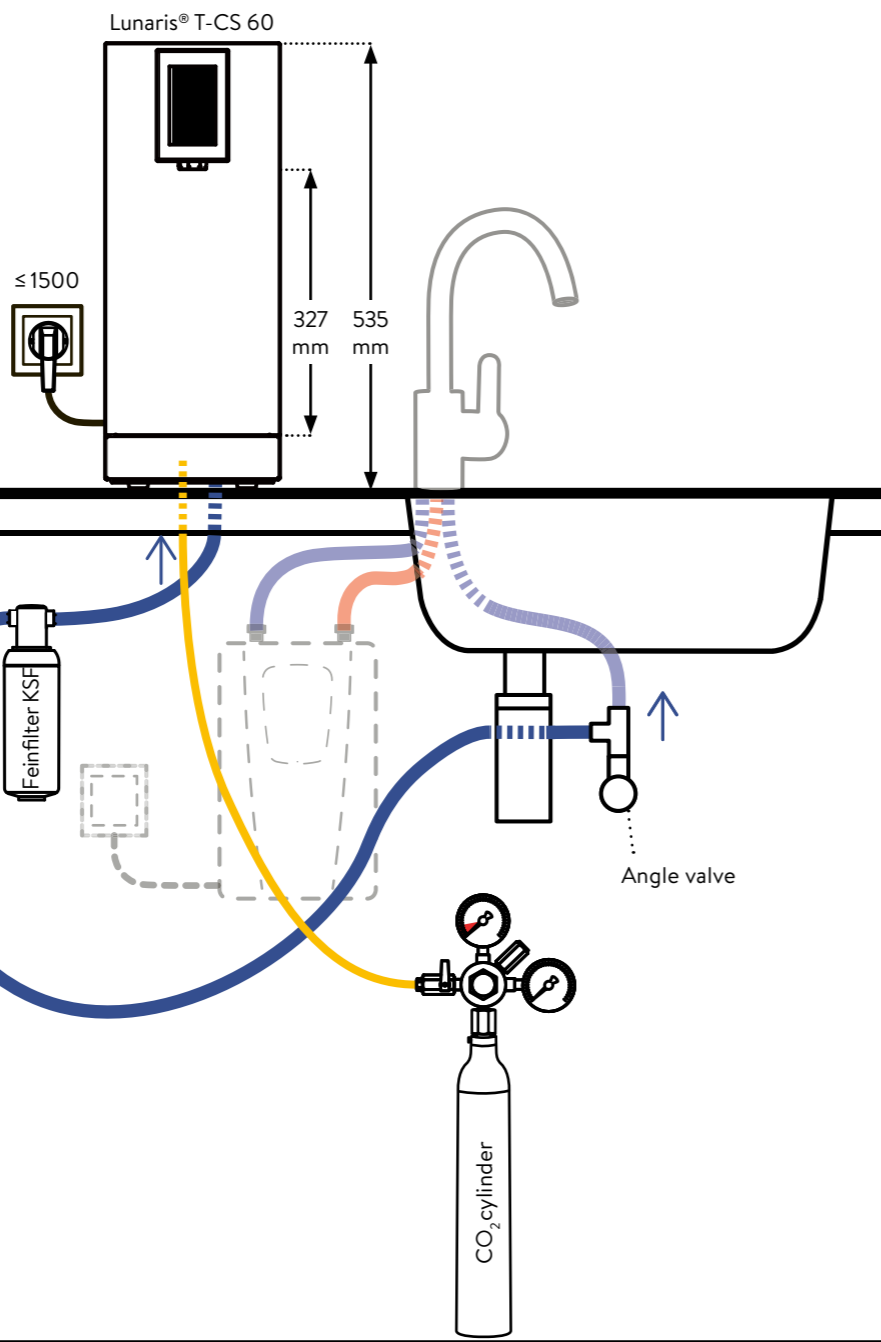
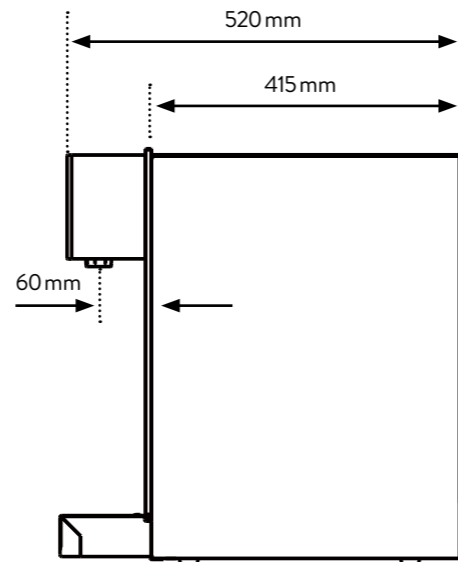

Lunaris® T-CS 60



Lunaris® T-CS 60 white Lunaris® T-CS 60 black

The Lunaris® T-CS 60 tabletop water dispenser provides up to **60 litres per hour of consistently chilled and carbonated water. Perfect for small offices, medical practices, staff rooms or nurseries.**

- > Electronic water system for supplying filtered, chilled or sparkling table water for direct connection to an angle valve
- > Touch display for menu control and water selection
- > Supplies up to 100 people
- > Uses R290 refrigerant to meet all environmental and climate protection requirements
- > Efficient and powerful, the patented COOL-HYBRID® System combines the advantages of ice banks and dry cooling (30% higher cooling capacity and **up to 30% energy savings compared to conventional water dispensers**).
- > The patented KARBONY® System produces up to 2.2 litres of sparkling water in just 35 seconds with the **perfect balance between water temperature and carbon dioxide content.**
- > **Triple protection against germs:** the Tyfon® System uses three technologies to keep the machine, dispenser and drip tray germ-free
- > Up to 60 litres per hour of consistently chilled and sparkling water
- > Comprehensive connection accessories such as Vario-san additional device valve (for additional connection to an already occupied water connection), water stop for additional safety, backflow preventer in accordance with DIN EN 1717 and other necessary connection accessories



- Accessories required for installation (not included in delivery, see page 77):
- > Lunaris® filter head set LFS (Part number: 4100-45020)
 - > Dirt filter KSF (Part number: 845060)
 - > Lunaris® Pressure reducer DMCS (Part number: 4100-45021)
 - > CO₂-Gas cylinder with 1/14 inch thread (available from specialist gas retailers)

| Lunaris® T-CS 60 | |
|---|---------------------------------------|
| Function: | |
| Number of users: | < 100 |
| Water connection (thread connection): | G 3/4" |
| Zulässiger Wasserdruck [bar]: | 2.0 - 6.0 |
| Zulässiger CO ₂ -Druck [bar]: | 3.0 - 5.5 |
| Temperature of cooled water [°C]: | 4 - 12 |
| Chilled water capacity [glasses ²⁾ / h]: | 300 ²⁾ |
| Standby power consumption [kWh / 24h]: | 0.43 |
| Nominal power at voltage 1~/N/PE 230 V AC [kW]: | 0.32 |
| Power cable: | with plug |
| Current [A]: | 1.55 |
| Protection class: | IP 22 |
| Weight (empty) [kg], approx.: | 34 |
| Dimensions (height x width x depth) [cm]: | 53.5 x 21.0 x 52.8 |
| Compact tabletop unit [colour]: | white black |
| Part number: | 4100-45002 4100-45003 |

Retail box: 51.7 x 21 x 52.8 cm / 24 kg PU = 1 1) Standard glass with 200 ml 2) At Δt = 10 °C

**Base cabinet
LUS-W / LUS-S**

- > Modern base cabinet with wall bracket
- > Drip tray drain
- > CO₂ cylinder strap
- > Lockable with 2 keys
- > Bracket for water filter head
- > Mounting points for water filter head



| | LUS-W | LUS-S |
|---|-----------------------|------------|
| Suitable for: | Lunaris® T-CS 20 / 60 | |
| Colour: | white | black |
| Dimensions (height × width × depth) [cm]: | 540 × 380 × 920 | |
| Part number: | 4100-45010 | 4100-45011 |

Retail box: 58 × 58 × 96 cm / 25 kg PU = 1

**Schmutzfilter
KSF**



- > KSF dirt filter cartridge for water systems
- > Natural coconut membrane filtration of odour and taste residues, chlorine, organic pollutants, medication and hormone residues
- > Improves the taste of water
- > Reduces maintenance requirements
- > The filter cartridges are hygienic and easy to replace
- > **Filter head must be ordered separately**

| | KSF |
|---|------------------|
| Suitable for: | Lunaris® T-CS 60 |
| Dimensions incl. filter head (height × Ø) [cm]: | 29 × 7.5 |
| Capacity at 10°KH [litres]: | approx. 6.000 |
| Part number: | 845060 |

Retail box: 32 × 25 × 8 cm / 0.54 kg PU = 1

**Water filter
LSF**



- > Activated carbon filter system with integrated high-performance pre-filtration
- > Reduction of particles, off-flavour components and chlorine
- > Filters solids down to a size of 1 µm and complies with NSF Standard 42

| | LSF |
|-----------------------------|------------------|
| Suitable for: | Lunaris® T-CS 20 |
| Capacity at 10°KH [litres]: | approx. 10.000 |
| Part number: | 845201 |

Retail box: 25 × 10 × 10 cm / 0.54 kg PU = 1



LUS-S base cabinet in black for flexible installation of the Lunaris® T-CS 20/60 water dispenser.

**Lunaris®
filter head set
LFS**



- > Lunaris® filter head set for external connection

| | LFS |
|---------------|------------------|
| Suitable for: | Lunaris® T-CS 60 |
| Part number: | 4100-45020 |

Retail box: 25 × 15 × 10 cm / 0.53 kg PU = 1

**CO₂
disposable bottle**



- > 600 g disposable CO₂ cylinder E290 Carbon dioxide M10 × 1

| | CO ₂ Disposable bottle |
|---------------|-----------------------------------|
| Suitable for: | Lunaris® T-CS 20 |
| Part number: | 845204 |

Retail box: 7.5 × 7.5 × 31 cm / 1.71 kg PU = 1

**Pressure reducer
DMCS**



- > Pressure reducer with standard CO₂ connection thread (1/14 inch) for CO₂ cylinders, usually from 1000 g
- > With adapter from 1/4 inch external thread to John Guest quick connector 6 mm

| | DMCS |
|---------------|-----------------------|
| Suitable for: | Lunaris® T-CS 20 / 60 |
| Part number: | 4100-45021 |

Retail box: 18.5 × 13 × 22.5 cm / 1 kg PU = 10